



IN-COLUMN FREEZER - FROST FREE



PRODUCT CODE

RiF1796

DIMENSIONS

h: 1770mm

PERFORMANCE

e Energy class F
Noise class C
Energy consumption
289kWh/yr
Max. noise 40dB [A]
11.5kg / 24hr freezing
capacity

FINISH AVAILABLE

White

GENERAL FEATURES

- Matches RIL1796 fridge
- Reversible door
- Sliding door installation
- Electronic controls
- 4 star
- Frost free
- Top LED strip light
- Super freeze
- 1 Twist ice cube maker

DESIGN

- Deluxe steel trimmed interior
- Transparent plastic drawers

STORAGE

- 6 Drawers
- 2 flip down door compartments

CAPACITY

- 197 Litre total net capacity
- 221 Litre total gross capacity

DIMENSIONS

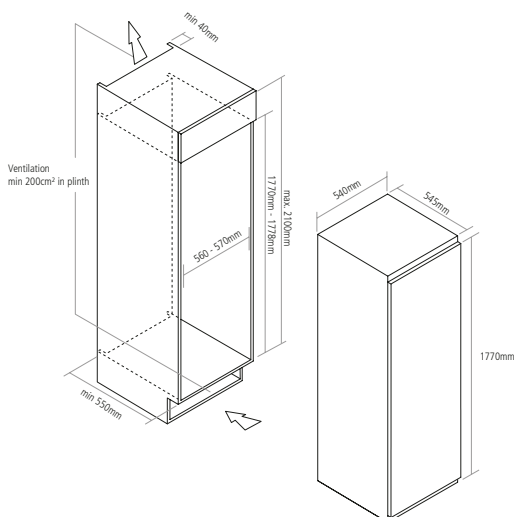

Features

FROST-FREE

No more laborious defrosting with a scraper. Our frost-free system works by heating up an element for a short time, which melts the ice and prevents build-up. Keeping a freezer ice-free means food stays fresher for longer. Freezing food is also much quicker, preserving as many nutrients as possible and freeing up much needed storage space.

LED LIGHTING & ELECTRONIC CONTROLS

Strip LED lighting adds a modern feel, while electronic controls are precise and easy to use.

TWIST ICE CUBE MAKER

The new twist ice cube maker is a convenient way to make ice, with the added benefits of easy removal for cleaning for those times when you need the extra space.