



Induction Hob Instruction Manual

C8761



Contact Cable on 0117 938 7420 for spare parts or www.cable.co.uk

Dear customers,

Congratulations on your purchase of a Caple induction hob.

In order to make the best use of your appliance, please carefully read the following use and care manual and keep it for reference.

SUMMARY

SAFETY	4
PRECAUTIONS BEFORE USING.....	4
USING THE APPLIANCE	5
PRECAUTIONS NOT TO DAMAGE THE APPLIANCE	6
PRECAUTIONS IN CASE OF APPLIANCE FAILURE.....	7
OTHER PROTECTIONS	7
ENVIRONMENTAL PROTECTION	8
CE DECLARATIONS OF CONFORMITY	8
WARRANTY	8
UKCA DECLARATIONS OF CONFORMITY	8
TECHNICAL FICHE	8
DESCRIPTION OF THE APPLIANCE	10
TECHNICAL CHARACTERISTICS.....	10
CONTROL PANEL	11
USE OF THE APPLIANCE	11
DISPLAY	11
VENTILATION.....	11
STARTING-UP AND APPLIANCE MANAGEMENT	12
BEFORE USING YOUR NEW INDUCTION HOB.....	12
HOW INDUCTION WORKS	12
TOUCH CONTROL	12
POWER SELECTION ZONE “SLIDER” AND TIMER SETTING ZONE	12
RESIDUAL HEAT INDICATION	12
PAN DETECTION	13
STARTING-UP.....	13
BOOSTER FUNCTION	13
TIMER	14
AUTOMATIC COOKING	15
PAUSE FUNCTION	15
RECALL FUNCTION.....	15
BRIDGE FUNCTION	16
“KEEP WARM” FUNCTION	16
CONTROL PANEL LOCKING.....	16
COOKING ADVICE	17
CHOOSING THE RIGHT COOKWARE	17
PAN DIMENSION.....	17
EXAMPLES OF COOKING POWER SETTINGS.....	18
MAINTENANCE AND CLEANING	18
TROUBLESHOOTING	18
INSTALLATION INSTRUCTIONS	21
ELECTRICAL CONNECTION	23

SAFETY

Precautions before using

- Unpack the hob and all associated components, taking care not to lose or mishandle any parts.
- The appliance must be installed by a suitably qualified professional and connected to the electricity supply by a qualified electrician who will comply with the local regulations. The manufacturer cannot be held responsible for damage caused by wrong installation or connection.
- The appliance must be installed in a purpose-designed kitchen unit and worktop cut out as specified below.
- This appliance is intended to be used in household and similar applications such as:
 - Staff kitchen areas in shops, offices and other working environments.
 - Farm Houses.
 - By clients in hotels, motels and other residential type environments.
 - Bed and breakfast type environments.
- Remove all labels and other packaging materials from the ceramic surface prior to use.
- Do not modify the appliance in any way as this will invalidate the guarantee and is potentially dangerous.
- The hob must not be used as a freestanding appliance or as a worktop.
- This appliance must be connected to the electricity supply according to the local regulations. It must be suitably earthed.
- Do not use any extension cable to connect the hob.
- This appliance must not be installed above a dishwasher or tumble dryer as steam may damage the electronic components.
- This appliance must not be controlled by external tools like separate timer or separate remote control system.

Using the appliance

- Always switch cooking zones off after use.
- Take particular care when cooking with oils or fats that may ignite.
- Cooking pans and utensils and the hob itself become hot during use. Caution, risk of injury to people and pets both during and after use.
- Ensure no cable from any other appliance can come into contact with the hob top or pans during use.
- Magnetic objects (such as credit cards, portable electronic devices; etc.) must not be placed near the appliance during use.
- Metal objects such as knives, forks, lides etc. must not be placed on the hob as they may become hot.
- Don't place any other metallic object than suitable pans on the hob. In case of untimely activation or residual heat, metallic object may become hot, melt or even burn.
- Never cover the hob with any cloth or other cover. This may become hot and create a fire hazard.
- This appliance can be used by children aged from 8 years and above and persons with reduced physical, sensory or mental capabilities or lack of experience and knowledge if they have been given supervision or instruction concerning use of the appliance in a safe way and understand the hazards involved.
- Children shall not play with the appliance.
- Cleaning and user maintenance shall not be made by children without supervision.

Precautions not to damage the appliance

- Use of damaged pans or those with raw cast iron bottoms may damage the hob ceramic glass.
- Abrasive materials such as scouring cleaners and grits may damage the ceramic glass.
- Avoid dropping objects onto the ceramic glass.
- Take care not to strike the edges of the hob with saucepans.
- Ensure that ventilation remains free from obstructions and complies with instructions specified by the manufacturer.
- Do not place empty saucepans on the hob.
- Sugar, synthetic materials or aluminium foil must not come into contact with the heating zones. These may cause permanent damage to the ceramic. If these should accidentally fall onto the hob, turn it off immediately and carefully remove them. Take care not to burn yourself.
- **WARNING:** Unattended cooking on a hob with fat or oil can be dangerous and may result in fire.
- **CAUTION:** The cooking process has to be supervised. A short term cooking process has to be supervised continuously.
- **WARNING:** Danger of fire: do not store items on the cooking surface.
- Never place any hot items on the control panel.
- If a drawer is located below the hob, ensure that a minimum air gap of at least 4 cm is left between the drawer contents and the base of the hob. This is essential to guarantee correct ventilation. A horizontal divider made of material capable of withstanding 65°C above ambient temperature can be used to ensure this air gap.
- Never place inflammable items or materials (like sprays) in a drawer or cupboard below the hob. Cutlery drawers must be resistant to heat.

Precautions in case of appliance failure

- If a fault is noticed, switch off the appliance and turn off the electricity supply.
- There are no user-serviceable parts inside the appliance. Don't open the appliance by yourself. All repairs must be performed by a suitably qualified service engineer or similar.
- **WARNING:** If the ceramic glass is broken or cracked, don't use the appliance and turn off the electricity supply to avoid the possibility of electric shock. Contact after-sales service.
- See the troubleshooting section in this manual.

Other protections

- Ensure that each pan is well centred on its cooking zone. The pan base must cover as much of the cooking zone as possible.
- For those with heart pacemakers or active implants, the magnetic field could influence its operating. You should obtain information from the retailer or your attending physician.
- Do not use aluminium or plastic containers: they could melt onto hot cooking zones.
- **NEVER** try to extinguish a fire with water, but switch off the appliance and then cover flame e.g. with a lid or a fire blanket.



THE USE OF INCORRECT COOKWARE OR ANY INDUCTION ADAPTOR PLATE DESIGNED FOR NON-MAGNETIC COOKWARE WILL INVALIDATE THE GUARANTEE. THE MANUFACTURER CANNOT BE HELD RESPONSIBLE FOR ANY DAMAGE TO THE HOB AND/OR ITS ENVIRONMENT AS A RESULT OF SUCH USE.



ENVIRONMENTAL PROTECTION



Waste electrical products should not be disposed of with household waste. Please recycle where facilities exist. Check with your Local Authority or retailer for recycling advice. This appliance is marked according to the European directive on Waste Electrical and Electronic Equipment (WEEE).

By ensuring this product is disposed of correctly, you will help prevent potential negative consequences for the environment and human health, which could otherwise be caused by inappropriate waste handling of this product. The symbol on the product indicates that this product may not be treated as household waste. Instead it shall be handed over to the applicable collection point for the recycling of electrical and electronic equipment. Disposal must be carried out in accordance with local environmental regulations for waste disposal.

For more detailed information about treatment, recovery and recycling of this product, please contact your local council, your household waste disposal service or the retailer where you purchased the product.

CE DECLARATIONS OF CONFORMITY

This appliance has been manufactured to the strictest standards and complies with all applicable legislation, Low Voltage Directive (LVD) and Electromagnetic Compatibility (EMC).

WARRANTY

Your new appliance is covered by warranty. The warranty card is enclosed - if it is missing, you must provide the following information to your retailer in order to receive a replacement: date of purchase, model and serial number. Registration can also be completed online by visiting www.caple.co.uk.

Ensure you keep your warranty card safe, you may need to show it to Caple Service together with proof of purchase.

If you fail to show your warranty card you will incur all repair charges. Spare parts are only available from Caple Service and spare parts authorised centres.

UKCA DECLARATIONS OF CONFORMITY

This appliance has been manufactured to the strictest standards and complies with all applicable legislation.

TECHNICAL FICHE

This appliance conforms to all current and applicable regulations. To view the Technical Fiche that supports the energy labelling data, please visit the product page on our website www.caple.co.uk

DESCRIPTION OF THE APPLIANCE

Technical characteristics

Type	C876I
Total power	7100 W
Energy consumption for the hob EC_{hob}^{**}	176.9 Wh/kg
Front left heating zone	Ø 190 mm
Minimum detection	Ø 90 mm
Nominal power*	1400 W
Booster power*	2000 W
Standardised cookware category**	B
Energy consumption EC_{cw}^{**}	177.3 Wh/kg
Rear left heating zone	Ø 190 mm
Minimum detection	Ø 90 mm
Nominal power*	1400 W
Booster power*	-
Standardised cookware category**	B
Energy consumption EC_{cw}^{**}	177.3 Wh/kg
Rear right heating zone	Ø 220 mm
Minimum detection	Ø 100 mm
Nominal power*	2300 W
Booster power*	3000 W
Standardised cookware category**	C
Energy consumption EC_{cw}^{**}	171.1 Wh/kg
Front right heating zone	Ø 175 mm
Minimum detection	Ø 90 mm
Nominal power*	1400 W
Booster power*	-
Standardised cookware category**	A
Energy consumption EC_{cw}^{**}	181.9 Wh/kg

* The given power may change according to the dimensions and material of the pan.

** calculated according to the method of measuring performance (EN 60350-2).

Control panel

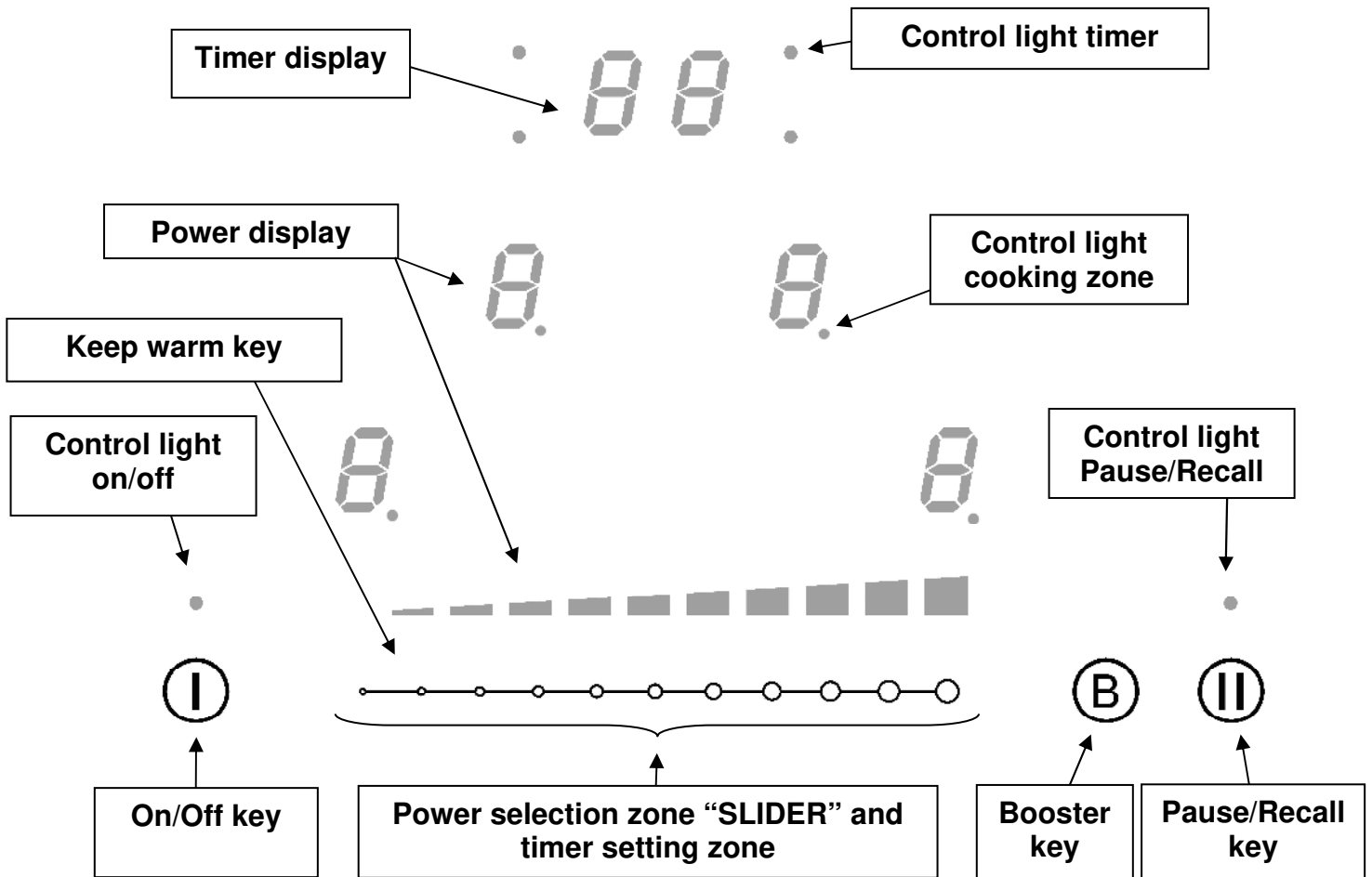

USE OF THE APPLIANCE

Display

<u>Display</u>	<u>Designation</u>	<u>Function</u>
0	Zero	The heating zone is activated.
1...9	Power level	Selection of the cooking level.
U	Pan detection	No pan or inadequate pan.
A	Heat accelerator	Automatic cooking.
E	Error message	Electronic failure.
H	Residual heat	The heating zone is hot.
P	Booster	The boosted power is activated.
L	Locking	Control panel locking.
U	Keep warm	Maintain automatically of 70°C.
II	Pause	The hob is in pause.
□	Bridge	2 cooking zones are combined.

Ventilation

The cooling system is fully automatic. The cooling fan starts with a low speed when the calories brought out by the electronic system reach a certain level. The ventilation will run at high speed when the hob is intensively used. The cooling fan reduces speed and stops automatically when the electronic circuit is cooled enough.

STARTING-UP AND APPLIANCE MANAGEMENT

Before Using Your New Induction Hob

Clean your hob with a damp cloth, and then dry the surface thoroughly. Do not use detergent, as this risks causing blue-tinted colour on the glass surface.

How Induction Works

An induction coil is located under each heating zone. When it is engaged, it produces a variable electromagnetic field which produces inductive currents in the ferromagnetic bottom plate of the pan. As a result, the pan will heat up.

Of course the pan has to be adapted:

- All ferromagnetic pans are recommended (please verify it thanks a little magnet): cast iron and steel pans, enamelled pans, stainless-steel pans with ferromagnetic bottoms...
- Are excluded: copper, pure stainless-steel, aluminium, glass, wood, ceramic, stoneware,...

The induction heating zone is able to automatically detect the size of a pan. If the base diameter of the pan is too small and therefore fails to adapt to the induction hob, the display will show [U].

Touch Control

Your induction hob is equipped with electronic controls with touch control keys. When your finger presses the key, the corresponding command is activated. This activation is validated by a control light, a letter or a number in the display and/or a “beep” sound.

For general use, ensure only one button is pressed at any time.

Power selection zone “SLIDER” and timer setting zone

To select the power with the slider, slide your finger on the “SLIDER” zone. You can already have a direct access if you put your finger directly on the chosen level.

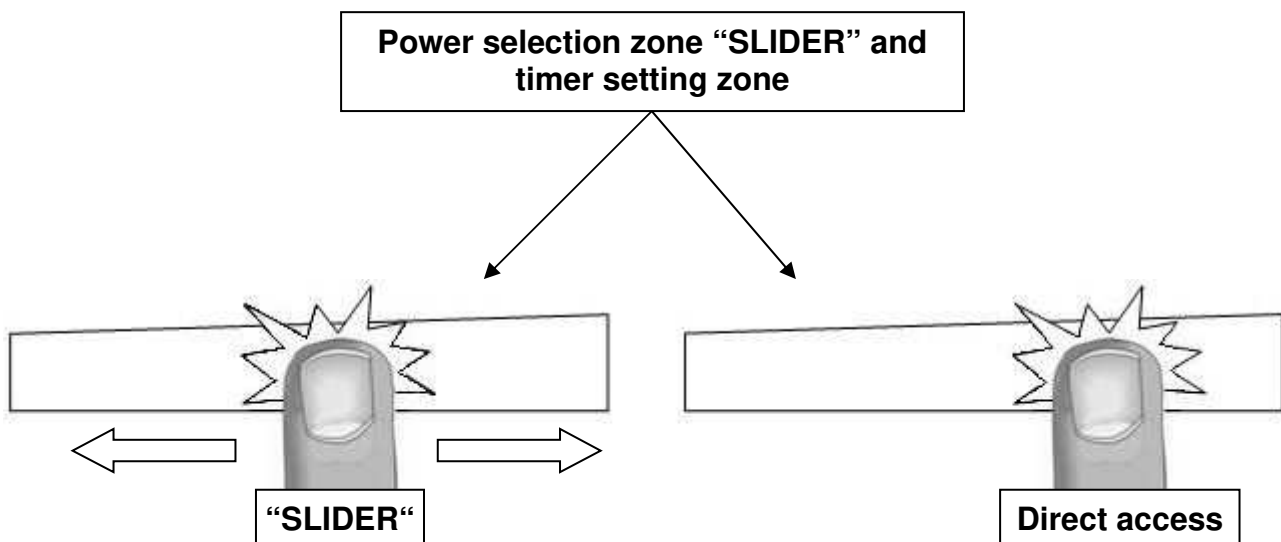

Residual heat indication

After a heating zone or the entire hob is switched off, the heating zones are still hot and indicate [H] on the display.

The symbol [H] disappears when the heating zones may be touched without danger.

While the residual heat indicator light is on, don't touch the heating zones and don't put any heat sensitive object on them. **There are risks of burn and fire.**

Pan detection

The pan detection feature ensures safety. The induction doesn't work:

- If there is no pan on the heating zone or if the pan is not adapted to the induction. In this case, it is impossible to increase the power and the display shows [U]. This symbol disappears when a suitable pan is put on the heating zone.
- If the pan is removed from the heating zone the operation is stopped. The display shows [U]. The symbol [U] disappears when the pan is put back to the heating zone. The cooking continues with the power level set before.

After use, switch the heat element off: don't let the pan detection [U] active.

Starting-up

- **Start-up / switch off the hob:**

<u>Action</u>	<u>Control panel</u>	<u>Display</u>
To start	Press key [①]	[0] are blinking
To stop	Press key [①]	Nothing or [H]

- **Start-up / switch off a heating zone:**

<u>Action</u>	<u>Control panel</u>	<u>Display</u>
Zone selection	Press display [0] selected	[0] and control light on
To set (adjust the power)	Slide on the "SLIDER" to the right or to the left	[0] to [9]
To stop	Slide to [0] on "SLIDER" or press on [0]	[0] or [H] [0] or [H]

If no action is made within 20 seconds, the electronics returns in waiting position.

Booster function

The booster function [P] grants a boost of power to the selected heating zone.

If this function is activated the heating zones work for 10 minutes with an ultra-high power.

The booster is used for example, to rapidly heat up big quantities of water.

- **Start-up / Stop the booster function:**

<u>Action</u>	<u>Control panel</u>	<u>Display Zone</u>
Zone selection	Press key [0] from the zone	[0] and control light on
Start up the booster	Press key [②]	[P]
Stop the booster	Slide on the "SLIDER" or press on [P]	[P] to [0] [9]

- **Power management:**

If the selected heating levels for both zones exceed the maximum available amount of power, the power management function will automatically reduce the power from one of these zones. The display of this zone will blink first; the level is then automatically reduced to the highest suitable position.

Heating zone selected

[P] is displayed

The other heating zone: (example: power level 9)

[9] goes to [6] or [8] depending the type of zone

Timer

The timer can be used with all heating zones simultaneously and with different time settings (from 0 to 99 minutes) for each heating zone.

- **Setting and modification of the cooking time:**

Example for 16 minutes at power 7:

<u>Action</u>	<u>Control panel</u>	<u>Display</u>
Zone selection	Press display [0] selected	[0] and control light on
Select the power level	Slide on the "SLIDER" to [7]	[7]
Select « Timer »	Press display [CL]	[00]
Set the units	Slide on the "SLIDER" to [6]	[0 fixed] [6 blinking]
Valid the units	Press display [06]	[0 blinking] [6 fixed]
Set the tens	Slide on the "SLIDER" to [1]	[1 blinking] [6 fixed]
Valid the tens	Press display [16]	[16]

The time is confirmed and the timer starts.

- **To stop the cooking time:**

Example for 13 minutes at power 7:

<u>Action</u>	<u>Control panel</u>	<u>Display</u>
Zone selection	Press display [0] selected	[0] and control light on
Select « Timer »	Press key [13]	[13]
Deactivate the units	Slide on the "SLIDER" to [0]	[1 fixed] [0 blinking]
Valid the units	Press display [10]	[1 blinking] [0 fixed]
Deactivate the tens	Slide on the "SLIDER" to [0]	[0 blinking] [0 fixed]
Valid the tens	Press display [00]	[00]

- **Egg timer function:**

Egg timer is an independent function. It stops as soon as a heating zone starts up. If the egg timer is on and the hob is switched off, the timer continues until time runs out.

Example for 29 minutes:

<u>Action</u>	<u>Control panel</u>	<u>Display</u>
Activate the hob	Press display [①]	Zone control lights are on
Select« Timer »	Press display [CL]	[00]
Set the units	Slide on the "SLIDER" to [9]	[0 fixed] [9 blinking]
Valid the units	Press display [09]	[0 blinking] [9 fixed]
Set the tens	Slide on the "SLIDER" to [2]	[2 blinking] [9 fixed]
Valid the tens	Press display [29]	[29]

After a few seconds the control light stops blinking. The time is confirmed and the timer starts.

- **Automatic stop at the end of the cooking time:**

As soon as the selected cooking time is finished the timer displays blinking [00] and a sound rings. To stop the sound and the blinking it is enough to press the key [00].

Automatic cooking

All the cooking zones are equipped with an automatic cooking device. The cooking zone starts at full power during a certain time, and then automatically reduces its power on the pre-selected level.

- **Start-up:**

<u>Action</u>	<u>Control panel</u>	<u>Display</u>
Zone selection	Press display [0] selected	[0] and control light on
Full power setting	Slide on the "SLIDER" to [9]	Pass from [0] to [9]
Automatic cooking	Re-press on display "SLIDER" [9]	[9] is blinking with [A]
Power level selection (for example " 7 ")	Slide on the "SLIDER" to [7]	[9] pass to [8] [7] [7] is blinking with [A]

- **Switching off the automatic cooking:**

<u>Action</u>	<u>Control panel</u>	<u>Display</u>
Zone selection	Press [7] from the zone	[7] blinking with [A]
Power level selection	Slide on the "SLIDER"	[1] to [9]

Pause function

This function brakes all the hob's cooking activity temporarily and allows you to restart with the same settings.

- **Startup/stop the pause function:**

<u>Action</u>	<u>Control panel</u>	<u>Display</u>
Engage pause	Press [⏸] during 2s	Displays [II] in the heating zone displays
Stop the pause	Press [⏸] during 2s	Pause control light is blinking
	Press another touch or slide on the "SLIDER"	Pause control light is off

Recall function

After switching off the hob (⏻), it is possible to recall the last settings.

- Cooking stages of all cooking zones (power)
- Minutes and seconds of programmed cooking zone-related timers
- Heat up function

The recall procedure is following:

- Press the key [⏻]
- Then press the key [⏸] within 6 seconds

The precedent settings are activated.

Bridge function

This function allows to use the 2 cooking zones at the left at same time with the same features as a single cooking zone. Booster function isn't allowed.

<u>Action</u>	<u>Control panel</u>	<u>Display</u>
Activate the hob	Press display [①]	[0] or [H] on the 4 displays
Activate the bridge	Press on the 2 left cooking zones	[0] appears on the front zone [□] on the rear zone.
Increase bridge	Slide on the "SLIDER "	[1 to 9] or [U]
Stop the bridge	Press on the 2 cooking zones links	[0] or [H] on the 2 zones

"Keep warm" function

This function allows you to reach and automatically maintain the temperature of 70°C. This will avoid liquids overflowing and fast burning at the bottom of the pan.

- **To engage, to start the function « Keep warm » :**

<u>Action</u>	<u>Control panel</u>	<u>Display</u>
Zone selection	Press display [0] selected	[0] to [9] or [H]
To engage	Press between 0 and 1 on the "SLIDER"	[U]
To stop	Press between 0 and 1 selected Slide on the "SLIDER"	[U] [0] to [9] or [H]

This function can be started independently on all the heating zones.

When the pan leaves the cooking zone of the "Keep warm" function remains active during approximately 10 minutes.

The maximum duration of keep warm is 2 hours.

Control panel locking

To avoid modifying a setting of cooking zones, in particular during of cleaning the control panel can be locked (with exception to the On/Off key [①]).

- **Locking:**

<u>Action</u>	<u>Control panel</u>	<u>Display</u>
Start	Press on key [①]	[0] or [H] on the displays
Hob locking	Press simultaneously [②] and [0] from the front right zone display Re-press on display [0]	No modification [L] on the displays

- **Unlocking:**

<u>Action</u>	<u>Control panel</u>	<u>Display</u>
Start	Press on key [①]	[L] on the displays

In the 5 seconds after start:

Unlocking the hob displays	Press simultaneously [②] and [L] from the front right zone display Press on key [②]	[0] or [H] on the No light on the displays
----------------------------	--	---

COOKING ADVICE

Choosing the Right Cookware

Adapted materials: steel, enamelled steel, cast iron, ferromagnetic stainless-steel, aluminium with ferromagnetic bottom.

Non-adapted materials: aluminium and stainless-steel without ferromagnetic bottom, copper, brass, glass, ceramic, porcelain.

Look for the induction symbol on the packaging or on the bottom of the pan.

To check if pans are compatible:

- Put some water in a pan placed on an induction heating zone set at level [9]. If [U] does not appear and the water is heating, the pan is suitable.
- Move a magnet towards the base of the pan. If it is attracted and sticks to the pan, the pan is suitable.

Certain pans can make noise when they are placed on an induction cooking zone. This noise is normal and does not affect the cooking operation, nor does it mean a failure in the appliance.

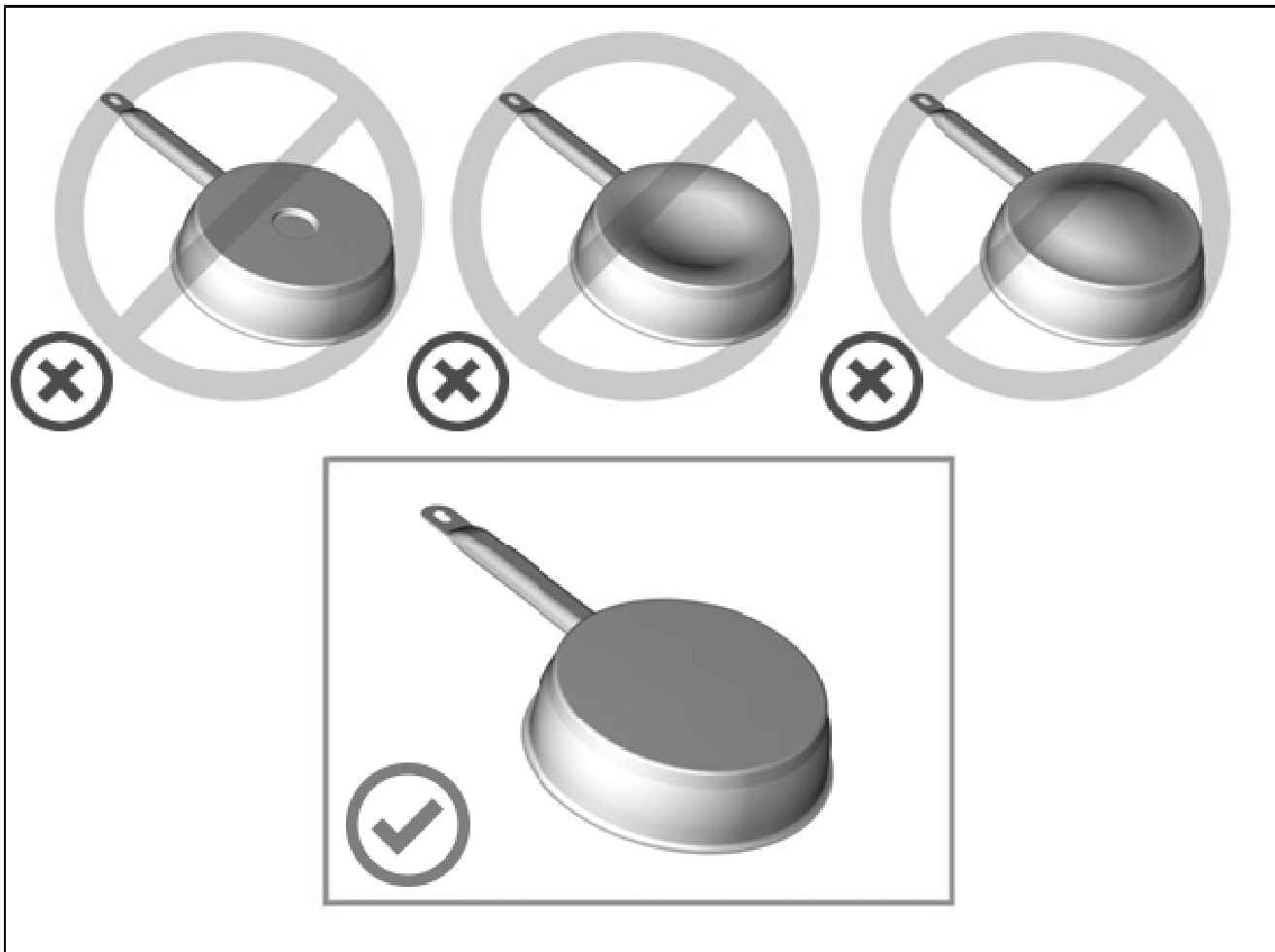

Do not use cookware with jagged edges or a curved base.

To avoid scratching the glass, always lift pans off the hob - do not slide

Pan dimension

The cooking zones are, until a certain limit, automatically adapted to the diameter of the pan. However, the bottom of this pan must have a minimum of diameter according to the corresponding cooking zone (see table on page 9 for the minimum pan diameter for each cooking zone).

To obtain the best efficiency of your hob, please place the pan well in the centre of the cooking zone.

Examples of cooking power settings

(the values below are indicative)

1 to 2	Melting Reheating	Sauces, butter, chocolate, gelatine Dishes prepared beforehand
2 to 3	Simmering Defrosting	Rice, pudding, sugar syrup Dried vegetables, fish, frozen products
3 to 4	Steam	Vegetables, fish, meat
4 to 5	Water	Steamed potatoes, soups, pasta, fresh vegetables
6 to 7	Medium cooking Simmering	Meat, lever, eggs, sausages Goulash, roulade, tripe
7 to 8	Cooking	Potatoes, fritters, wafers
9	Frying, roosting Boiling water	Steaks, omelettes, fried dishes Water
P	Frying, roosting Boiling water	scallops, steaks Boiling significant quantities of water

MAINTENANCE AND CLEANING

Switch-off the appliance before cleaning.

Do not clean the hob if the glass is too hot due to **risk of burns**.

- Remove light marks with a damp cloth with washing up liquid diluted in a little water. Then rinse with cold water and dry the surface thoroughly.
- Highly corrosive or abrasive detergents and cleaning equipment likely to cause scratches must be absolutely avoided.
- Do not use any steam-cleaner or pressure washer.
- Do not use any object that may scratch the ceramic glass.
- Ensure that the pan is dry and clean. Ensure that there are no grains of dirt on your ceramic hob or on the pan. Sliding rough saucepans will scratch the surface.
- Spillages of sugar, jam, jelly, etc. must be removed immediately. You will thus prevent the surface being damaged.

TROUBLESHOOTING

The hob or the cooking zone doesn't start-up:

- The hob is badly connected on the electrical network.
- The protection fuse cut-off.
- The locking function is activated.
- The sensitive keys are covered of grease or water.
- An object is put on a key.

The control panel displays [U]:

- There is no pan on the cooking zone.
- The pan is not compatible with induction.
- The bottom diameter of the pan is too small.

The control panel displays [E]:

- Call the After-sales Service.

The control panel displays [L]:

- Refer to the chapter control panel locking page.

One or all cooking zone cut-off:

- The safety system functioned.
- You forgot to cut-off the cooking zone for a long time.
- One or more sensitive keys are covered.
- The pan is empty and its bottom overheated.
- The hob also has an automatic reduction of power level and breaking Automatic overheating.

Continuous ventilation after cutting off the hob:

- This is not a failure, the fan continuous to protect the electronic device.
- The fan cooling stops automatically.

The automatic cooking system doesn't start-up:

- The cooking zone is still hot [H].
- The highest power level is set [9].

The control panel displays [U]:

- Refer to the chapter "Keep warm".

The control panel displays [II]:

- Refer to the chapter "Pause".

The control panel displays [□]:

- Refer to the chapter "Bridge".

When the symbol [E 4] appears:

- The table must be reconfigured. Please implement the following steps:

I) Important: before you start, make sure there is no more pot on the hob.

II) Disconnect the appliance from the grid by removing the fuse or turning the circuit breaker off.

III) Reconnect the table to the grid.

IV) Procedure:

* take a pot with a ferromagnetic bottom and a minimum diameter of 16 cm.

* start the procedure within 2 minutes after reconnecting the hob to the grid.

* don't use the [Ⓜ] touch.

V) First step: cancel the existing configuration.

1) Press the touch n°2 and hold down.

2) The symbol [-] will appear on each display.

3) With your other hand, press successively and quickly (less than 2s) on each [-] display.

Begin from the front right side and turn contrary clockwise, as described on the picture (from a to d).

A double "beep" means an error occurred. If so, start again from item 1).

4) Remove your fingers from the touch control, then push again on touch 1 during few seconds, until blinking [E] symbols appear.

5) Wait until [E] symbols stop blinking.

6) After few seconds, [E] are automatically transformed in [C]. The existing setup has been cancelled.

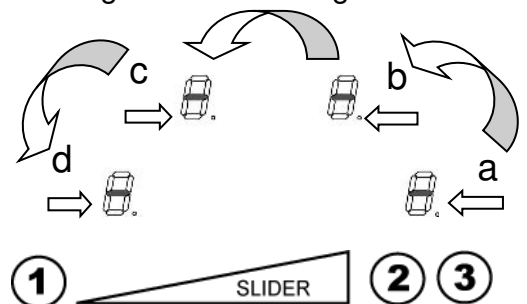

VI) Second step: new setup.

- 1) Take a ferromagnetical pot with a minimum diameter of 16 cm.
 - 2) Select a cooking zone by pushing on the corresponding [C] display.
 - 3) Place the pot on the area to be set.
 - 4) Wait until the [C] display becomes a [-]. The selected cooking zone is now configured.
 - 5) Follow the same procedure for each cooking zone with a [C] display.
 - 6) All the cooking zones are configured once all the displays are turned off.
- Please use the same pot for the whole procedure.
Never put several pots together on the zones during the setup-process.

- If [E 4] displaying remains, please call the customer care.

The control panel displays [] or [Er03]:

- An object or liquid covers the control keys. The symbol disappears as soon as the key is released or cleaned.

The control panel displays [E2] or [E H]:

- The hob is overheated, let it cool and then turn it on again.

The control panel displays [E3]:

- The pan is not adapted, change the pan.

The control panel displays [E6]:

- Defective network. Control the frequency and voltage of the electrical network.

The control panel displays [E8]:

- The air inlet of the ventilator is obstructed, release it.

The control panel displays [E C]:

- Configuration error. Set the table again, referring to the chapter "The [E 4] appears".

If one of the symbols above persists, contact Caple Service.

T - 0117 938 7420

E - service@caple.co.uk.

INSTALLATION INSTRUCTIONS

The installation comes under the exclusive responsibility of specialists.
 The installer is held to respect the legislation and the standards enforced in their country.

How to stick the gasket:

The gasket supplied with the hob avoids all infiltration of liquids in the cabinet.
 Installation has to be done carefully, in conformity with the following drawing.

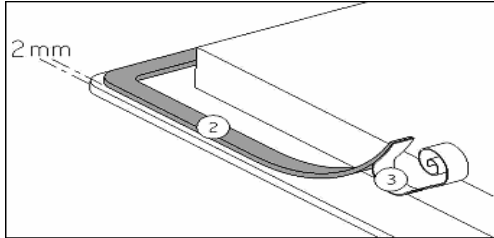

Stick the gasket (2) two millimeters from the external edge of the glass, after removing the protection sheet (3).

Fitting - installing:

- **The cut-out sizes and flush mounting:**

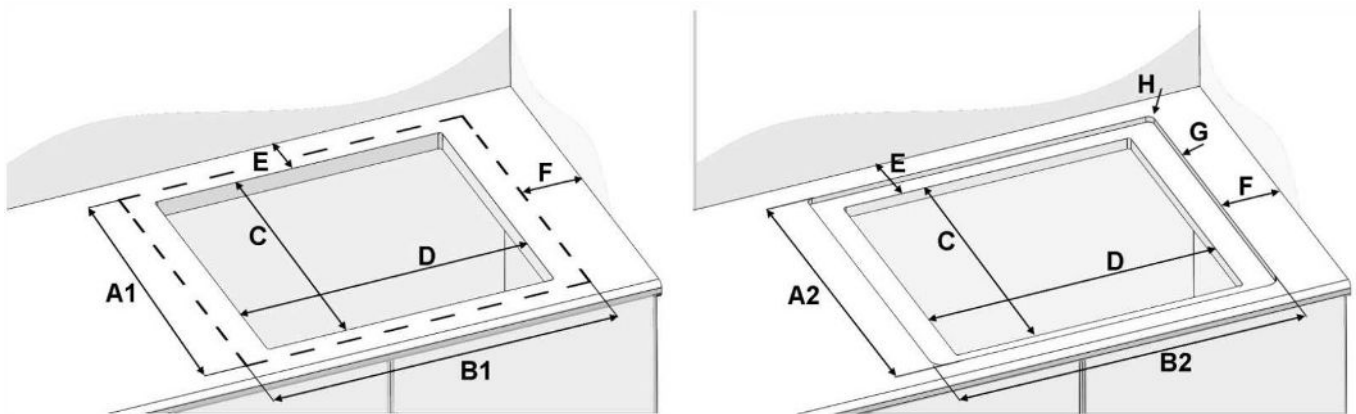

Glass		Cut size		Rear	Side	Radius	Cut size		Deep
A1	B1	C	D	E	F	H	A2	B2	G
380	900	360	880	50	40	8	386	906	5

- **Ensure that there is a distance of 50mm between the hob and the wall or sides.**
- The hobs are classified as “Y” class for heat protection. Ideally the hob should be installed with plenty of space on either side. There may be a wall at the rear and tall units or a wall at one side. **On the other side, however, no unit or divider must stand higher than the hob.**
- The piece of furniture or the support in which the hob is to be fitted, as well as the edges of furniture, the laminate coatings and the glue used to fix them, must be able to resist temperatures of up to 100°C.
- The wall or splashback behind the hob must be heat-resisting.
- Not to install the hob to the top of a not ventilated oven or a dishwasher.
- **There must be a space of 20mm beneath the bottom of the hob casing** to ensure a good air circulation of the electronic device. (See page 21 for full ventilation information)
- If a drawer is placed under the worktop, avoid placing flammable objects (for example: sprays) or not heat-resistant objects inside.
- Materials which are often used to make worktops, expand on contact with water. To protect the cut-out edge, apply a coat of varnish or special sealant. Particular care must be given to applying the adhesive joint supplied with the hob to prevent any leakage into the supporting furniture. This gasket guaranties a correct seal when used in conjunction with smooth work top surfaces.

- The safety gap between the hob and the cooker hood placed above must respect the indications of the hood manufacturer. In case of absence of instructions, use a minimum distance of 600mm.
- After installation, make sure the connection cord is not being constrained e.g. by the drawer.
- **WARNING:** Only use hob guards designed by the manufacturer, indicated as suitable in the manufacturer's instructions for the appliance, or those that have been incorporated into the appliance. The use of inappropriate guards can cause accidents.

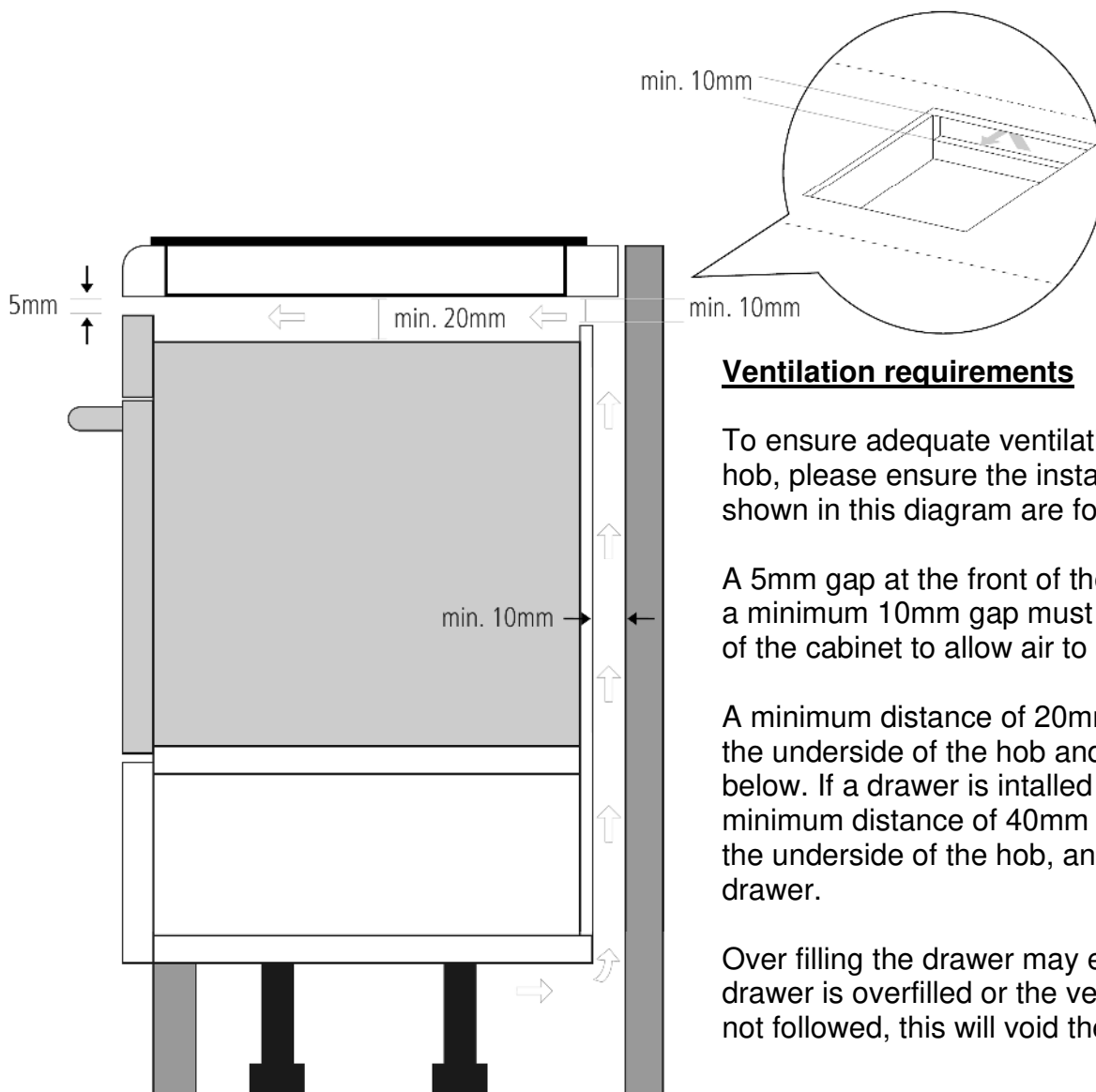

Ventilation requirements

To ensure adequate ventilation of your induction hob, please ensure the installation requirements shown in this diagram are followed.

A 5mm gap at the front of the unit must be left, and a minimum 10mm gap must be cut out at the back of the cabinet to allow air to circulate.

A minimum distance of 20mm must be left between the underside of the hob and the appliance directly below. If a drawer is installed below the hob, a minimum distance of 40mm must be left between the underside of the hob, and the contents of the drawer.

Over filling the drawer may effect the airflow. If the drawer is overfilled or the ventilation requirements not followed, this will void the guarantee.

ELECTRICAL CONNECTION

- The installation of this appliance and the connection to the electrical network should only be carried out by a qualified electrician.
- When installing, make sure no part of the hob is under stress or tension.
- Necessary Connection data is placed on the hob casing near the connection box.
- Connection to the mains must be made using an earthed plug or via an omnipolar circuit breaking device with a contact opening of at least 3mm.
- The electrical circuit must be separated from the network by adapted devices, for example: circuit breakers, fuses or contactors.
- If the appliance is not fitted with an accessible plug, disconnecting means must be incorporated in the fixed installation, in accordance with the installation regulations.
- The inlet hose must be positioned so that it does not touch any of the hot parts of the hob or oven.

Caution!

This appliance has only to be connected to a network 230 V~ 50/60 Hz.

Always connect the Earth Wire.

Respect the connection diagram.

The connection box is located underneath at the back of the hob casing. To open the cover, use a medium screwdriver.

Mains	Connection	Cable diameter	Cable	Protection calibre
230V~ 50/60Hz	1 Phase + N	5 x 1,5 mm ²	H 05 VV - F H 05 RR - F	25 A *
400V~ 50/60Hz	2 Phases + N	5 x 1.5 mm ²	H 05 VV - F H 05 RR - F	16 A *

* calculated with the simultaneous factor following the standard EN 60 335-2-6

Connection of the hob

Setting up the configurations:

For the various kinds of connection, use the brass bridges which are in the box next the terminal

Monophase 230V~1P+N

Put the bridge between terminal 1 and 2,

Attach the earth to the terminal “earth”, the neutral N to terminal 4, the Phase L to one of the terminals 1 or 2.

Biphase 400V~2P+N

Attach the earth to the terminal “earth”, the neutral N to terminal 4, the Phase L1 to the terminal 1 and the Phase L2 to the terminal 2.

Caution! Frequent loosening and screwing of the screws on the connection box risks damaging the efficiency of the tightness once screwed. It is therefore advisable to keep screwing and unscrewing to a minimum.

Ensure that the cables are correctly inserted and tightly screwed down.

4 weeks after installation, a check should be made to ensure the electrical cables are still connected tightly and tightened further if necessary.

We cannot be held responsible for any incident resulting from incorrect connection or which could arise from the use of an appliance which has not been earthed or has been equipped with a faulty earth connection.

Notes:

Caple Service
Fourth Way
Avonmouth
Bristol
BS11 8DW

t: 0117 938 7420
e: service@caple.co.uk
www.caple.co.uk