

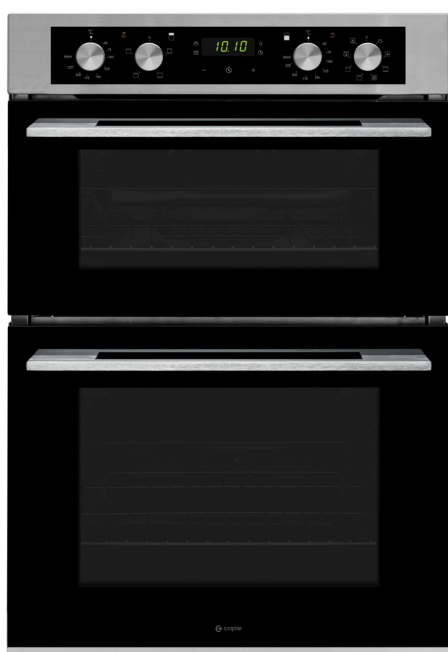

CAPLE CARE

FREE 2 YEAR
PARTS & LABOUR
GUARANTEE

CLASSIC ELECTRIC DOUBLE OVEN



DIMENSIONS

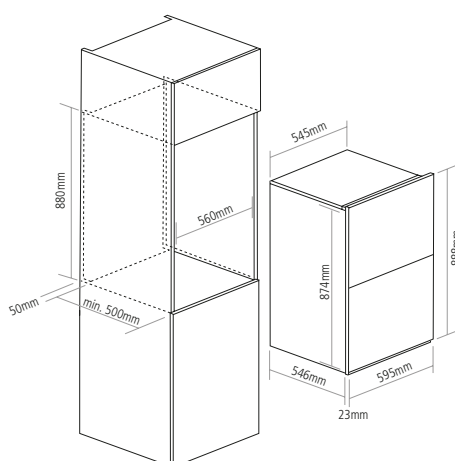

PRODUCT CODE

C C3249

DIMENSIONS

↔ w:595mm

PERFORMANCE

e Top Oven A
Bottom Oven A

FINISH AVAILABLE

■ Stainless steel with black glass

FUNCTIONS

4 Top Oven

- Conventional heat
- Full grill
- Base heat
- Top heat

8 Bottom Oven

- Light
- Turbo defrost
- Fan heat
- Turbo grill
- Conventional heat
- Turbo base heat
- Eco grill
- Full grill

OVEN FEATURES

Top Oven

- 40 Litre capacity

Bottom Oven

- 61 Litre capacity

GENERAL

- Triple glazed doors with heat reflective glass
- Easy clean enamel interior
- Removable chrome shelf racks
- Tangential cooling fan
- Touch control programmable electronic timer

DESIGN

- Stainless steel square bar handle
- Green LED display

ACCESSORIES

- 1 Safety-stop shelf in top oven
- 1 Safety-stop shelf in bottom oven
- 1 Grill pan with handle in top oven
- 1 Enamelled baking tray in bottom oven

OPTIONAL EXTRAS

- Spare shelf [SHELF3]
 - Pair of telescopic runners [CAPRACK7]
- Visit caple.co.uk for full range

INSTALLATION

- Diagram [p.216]
- Rated load 5.19kW
- Fuse rating 32A