

FULLY INTEGRATED SENSOR VENTED TUMBLE DRYER



PRODUCT CODE

TDi111

DIMENSIONS

↔ w:600mm

PERFORMANCE

e Energy Class C
Est. annual energy
consumption 519kWh/yr
Average energy by
cycle 4.39kWh
Max. noise level 62dB

FINISH AVAILABLE

White

OPTIONS

6 Sensor drying levels

Extra dry
Cupboard dry
Mid dry
Extra iron dry
Iron dry
Damp dry

FEATURES

- Vented drying
- 2 Heat settings
- 30 minute timed drying with heat
- 30 minute refresh
- Reverse tumble action
- Final cool down tumble
- Easy access fluff filter
- Rear vented only
- Integral extendable 2.4m hose and wall outlet
- Reversible appliance and furniture door
- Adjustable legs

CAPACITY

- 7kg drying capacity

INSTALLATION

- Electrical connection
- Rated load 2.7kW
- Fuse rating 13A

DIMENSIONS

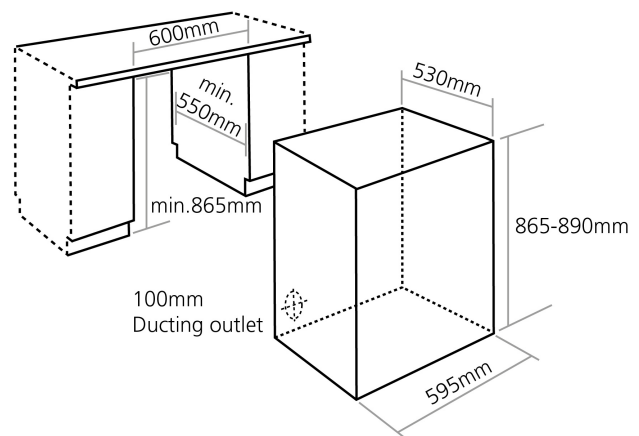

WASHING

TUMBLE DYER