



CAPLE CARE

FREE 2 YEAR
PARTS & LABOUR
GUARANTEE

ISLAND HOOD

PRODUCT CODE

Zi922

DIMENSIONS

 w:900mm

PERFORMANCE

e Energy class B
 Fluid dynamic efficiency B
 Light efficiency A
 Grease absorption D
 Annual Consumption
 54kWh/yr
 Max. extraction 581m³/h
 Max. noise level 66dB[A]

FEATURES

- Illuminated LED touch controls front and back
- 3 Speeds
- Large LED light panel
- Aluminium grease filters
- Required ducting size 150mm
- Recirculation kit available

OPTIONAL EXTRAS

- Recirculation kit [CAP61CF]
- Visit caple.co.uk for full range

DIMENSIONS

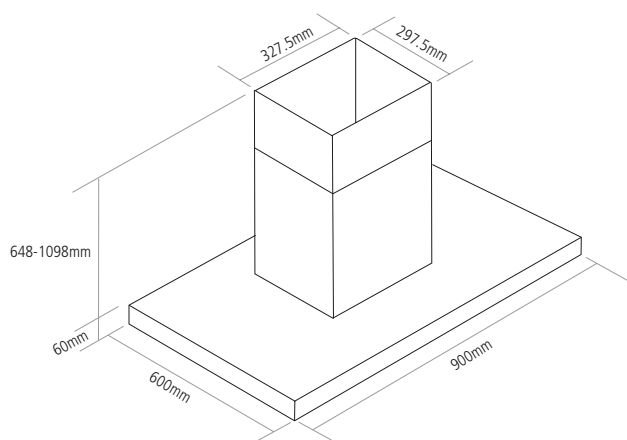

FINISH AVAILABLE

 Stainless steel with a black glass front panel