



Spirit Wall Chimney Hood Instruction Manual

SP612 / SP912



Contact Caple on 0117 938 7420 for spare parts or www.caple.co.uk

CONTENTS

Introduction	3
Safety instructions	4
Environmental protection	9
Installation	10
Operation	16
Care and maintenance	17
Troubleshooting	18
Product Dimensions	19
Caple Contact Details	20

INTRODUCTION

Thank you for choosing this Caple extractor hood.

To ensure that you get the best results from your new extractor, we strongly suggest that you read this instruction manual thoroughly before use. If treated with care, your Caple extractor should give you years of trouble-free use.

To register ownership, please follow the instructions on the guarantee card supplied with the appliance or visit www.caple.co.uk and register here.

This instruction manual is designed to provide you with all the required information related to the installation, use and maintenance of the appliance.

This hood is designed to extract unpleasant odours from the kitchen; it is not intended to extract steam. In order to operate the unit correctly and safely, please read this instruction manual carefully before installation and use.

The cooker hood uses high quality materials and is made with a streamlined design. Equipped with an electric motor and centrifugal fan, it provides strong extraction with low noise. It also features non-stick grease filters and an easy installation.

IMPORTANT NOTE:

This appliance must only be used for the purpose it is intended. Other types of use are not permitted and may prove dangerous. Caple will not be held liable for any damage caused by the incorrect use of the appliance.

Do not use any accessories or attachments not recommended by Caple as this may result in fire, electric shock or injury.

To protect against fire, electrical shock and injury to persons, do not immerse cords or plugs in water or any other liquid.

Never touch the appliance with wet or damp hands.

Never pull the power cable as you could damage it. If the appliance is faulty, do not attempt to repair it. Isolate it from the mains electric supply and contact Caple Service either by phone 0117 938 7420 or email service@caple.co.uk

Keep all packaging (including plastic bags, polystyrene foam etc) out of the reach and away from children.

Do not rest large or unstable objects on any part of the appliance.

IMPORTANT NOTE:

Caple cannot be held responsible for injuries or losses caused by incorrect use or installation of this product. Please note that Caple reserve the right to invalidate the guarantee supplied with this product following incorrect installation or misuse of the appliance. Under no circumstances should any external covers be removed for servicing or maintenance except by suitably qualified personnel.

SAFETY INSTRUCTIONS:

- Never let children operate the machine.
- The cooker hood is for home use only, not suitable for barbecuing, restaurants or other commercial purposes.
- The cooker hood and its filter should be cleaned regularly in order to keep in good working condition.
- Clean the cooker hood according to the instruction manual to reduce the risk of fire.
- When using a gas hob, do not leave naked flames under the extractor.
- Before connecting this appliance check that the power supply cord is not damaged.
- If the room where the hood is to be used contains a fuel burning appliance such as a central heating boiler then its flue must be of the sealed or balanced flue type. If other types of flue or appliances are fitted ensure that there is an adequate supply of air to the room.

- The air must not be discharged into a flue that is used for exhausting fumes from appliances burning gas or other fuels.
- Regulations concerning the discharge of air have to be conformed to.
- Do not flambé under the cooker hood.
- Never leave frying pans unattended during use as overheated fats and oils may catch fire.
- To ensure the best performance, we recommend switching on the extractor 15 minutes before cooking and leave it running 15 minutes after. This will ensure that the air in the kitchen is being circulated before cooking commences and the air is being cleaned after cooking has finished.
- The performance of your extractor will vary depending on a number of factors. These include type of extraction, room volume, length of ducting, ventilation available and the cleanliness of the filters.
- This appliance is not intended for use by persons (including children) with reduced physical, sensory or mental capabilities, or lack of experience and knowledge, unless they have been given supervision or instruction concerning use of the appliance by a person responsible for their safety.
- Children should be supervised to ensure that they do not play with the appliance.
- Cleaning and user maintenance must not be made by children without supervision.

- Never immerse the appliance in water.
- This appliance is intended to be used in household and similar applications such as:
 - › Staff kitchen areas in shops, offices and other working environments.
 - › Farm Houses.
 - › By clients in hotels, motels and other residential type environments.
 - › Bed and breakfast type environments.
- To avoid all risk, if the power cable is damaged, it must only be replaced by a Caple appointed engineer.
- Appliances can be used by persons with reduced physical, sensory or mental capabilities or lack of experience and knowledge if they have been given supervision or instruction concerning use of the appliance in a safe way and understand the hazards involved.
- Children must not play with this appliance.
- When not in use and before cleaning, always isolate the appliance from the electrical supply.

ELECTRICAL SHOCK HAZARD:

- Only plug this unit into a properly earthed outlet. If in doubt seek advice from a suitably qualified engineer.
- Failure to follow these instructions can result in death, fire, or electrical shock.

This appliance must be connected to the mains by a competent person. We recommend that the appliance is connected by a qualified electrician who is a member of the N.I.C.E.I.C who will comply with the I.E.E and local regulations. Electrical information can be found on the rating plate.



ENVIRONMENTAL PROTECTION

Waste electrical products should not be disposed of with household waste. Please recycle where facilities exist. Check with your Local Authority or retailer for recycling advice. This appliance is marked according to the European directive on Waste Electrical and Electronic Equipment (WEEE).

By ensuring this product is disposed of correctly, you will help prevent potential negative consequences for the environment and human health, which could otherwise be caused by inappropriate waste handling of this product. The symbol on the product indicates that this product may not be treated as household waste. Instead it shall be handed over to the applicable collection point for the recycling of electrical and electronic equipment. Disposal must be carried out in accordance with local environmental regulations for waste disposal.

For more detailed information about treatment, recovery and recycling of this product, please contact your local council, your household waste disposal service or the retailer where you purchased the product

WARRANTY

Your new appliance is covered by warranty. The warranty card is enclosed - if it is missing, you must provide the following information to your retailer in order to receive a replacement: date of purchase, model and serial number. Registration can also be completed online by visiting www.caple.co.uk.

Ensure you keep your warranty card safe, you may need to show it to Caple Service together with proof of purchase. If you fail to show your warranty card you will incur all repair charges.

Spare parts are only available from Caple Service and spare parts authorised centres.

CE DECLARATIONS OF CONFORMITY



This appliance has been manufactured to the strictest standards and complies with all applicable legislation, Low Voltage Directive (LVD) and Electromagnetic Compatibility (EMC).

UKCA DECLARATIONS OF CONFORMITY



This appliance has been manufactured to the strictest standards and complies with all applicable legislation.

TECHNICAL FICHE

This appliance conforms to all current and applicable energy regulations. To view the Technical Fiche that supports the energy labelling data, please visit the product page on our website www.caple.co.uk

INSTALLATION

PREPARE FOR THE INSTALLATION:

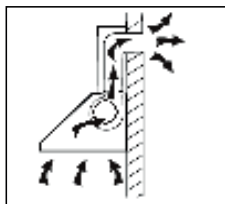

If you have an outlet to the outside, your cooker hood can be connected as per the below picture by means of an extraction duct with an interior diameter of 150mm.

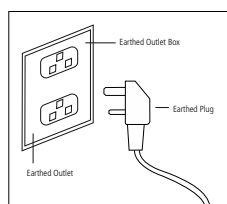

Before installation, turn the unit off and unplug it from the outlet.

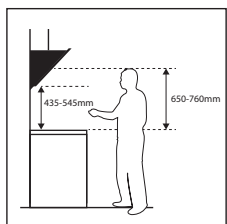

The cooker hood should be installed so that there is a space of 650-760mm from the centre of the mesh grease filters to the hob (435-545mm from the bottom of the hood to the hob). It is the manufacturer of the hob who determines the clearance required and the clearance quoted by the hob manufacturer must be followed. In the absence of any instructions supplied with a gas hob the minimum distance between the hob and the centre of the mesh grease filters must be at least 760mm.

INSTALLATION – DUCTED

ATTENTION:

When the cooker hood and appliance supplied with energy other than electricity are simultaneously in operation, the negative pressure in the room must not exceed 4 Pa (4×10⁻⁵ Bar).

Drill 3 holes using an 8mm drill bit to accommodate the bracket. Screw and tighten the bracket onto the wall with the screws (ST4x30mm) and wall plugs provided (A).

Level up the cooker hood and hang onto the wall bracket hook.

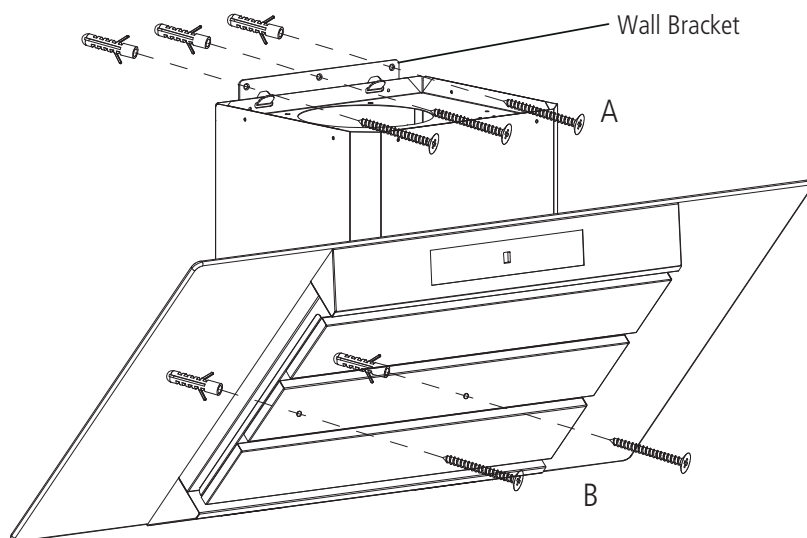

After hanging the hood on the bracket, open the front panel and remove the grease filters, mark 2 holes inside the hood for safety screws. After marking, remove the hood, drill two holes and insert 2 wall plugs. Hang the hood back onto the wall and finally fix the safety screws with 2 screws (ST4x30mm) (B).

CHIMNEY INSTALLATION

Attach the lower chimney section to the lower chimney bracket using the side hooks and mark the location of lower chimney bracket fixing holes on the wall.

After marking, drill two holes using an 8mm drill bit and insert 2 wall plugs. Fix the lower chimney bracket to the wall using 2 screws (ST4x30mm).

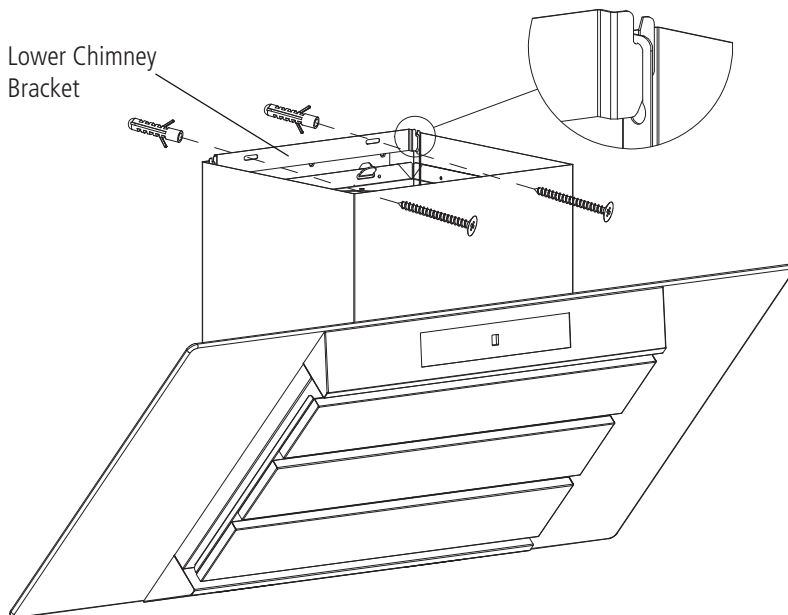

Place the plastic duct on the cooker hood outlet.

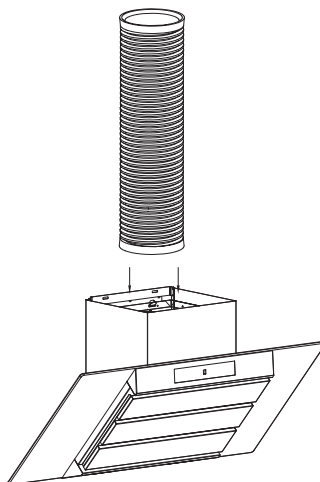

The upper chimney section sits inside the lower chimney section.

Mark the location of upper chimney bracket fixing holes on the wall. Drill two holes and insert 2 wall plugs. Fix the upper chimney bracket to the wall using 2 screws (ST4x30mm).

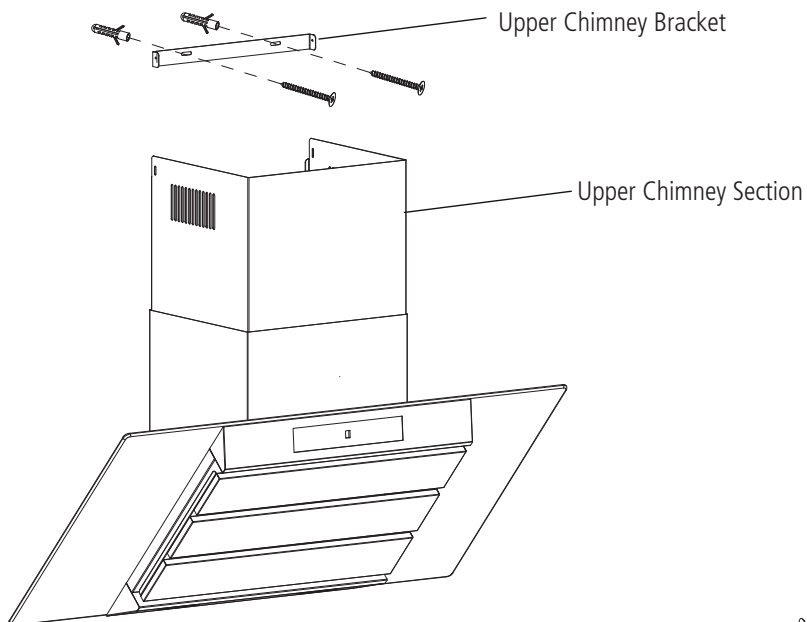

Pull the upper chimney section upwards to the target height, then fix to the upper chimney bracket using 2 screws (4x8mm).

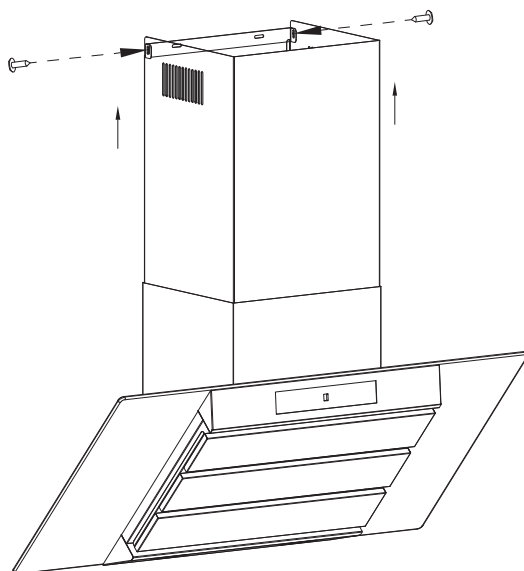

RECIRCULATION MODE

If you do not have an outlet to the outside, the exhaust pipe is not required (as shown in the section "Installation - ducted"), and charcoal filters must be installed.

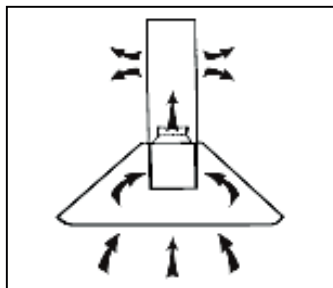

ACCESSING THE GREASE FILTER:

To access the grease filter, pull the bottom slat from the base upwards and it will lift up as shown below.

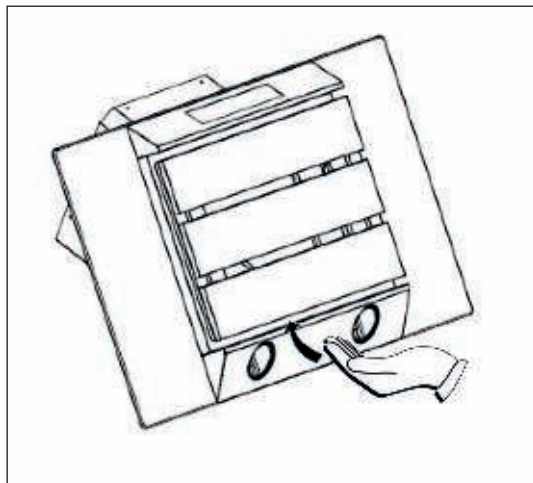

INSTALLING THE CHARCOAL FILTER (CAP61CF)

An activated charcoal filter can be used to trap odours. In order to install the charcoal filter, the grease filter should be detached first. Press the release button and pull it downward as shown below.



Fit the activated charcoal filter onto the side of the motor and turn it in a clockwise direction to lock into place. Repeat the same on the other side.

Scan the QR Code to access the 'How To' video.



NOTE:

Make sure the filter is securely locked. Otherwise, it may loosen and be dangerous.

When using a charcoal filter, the extraction power may be slightly reduced.

We recommend replacing these filters every 6 months. Replacement filters (CAP61CF) can be purchased directly from www.caple.co.uk

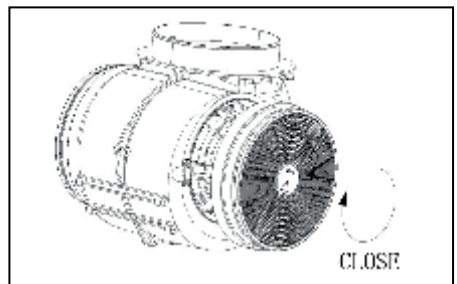

OPERATION - TOUCH CONTROL



- ⏻ ON/OFF BUTTON**
Press and hold for 2-3 seconds to turn the extractor fan on.
You can then change the speeds as per below. Press again to switch off.
- 1 LOW SPEED BUTTON**
Is suitable for simmering and cooking which does not produce much steam or odour.
- 2 MEDIUM SPEED BUTTON**
Airflow speed is ideal for extracting with standard cooking.
- 3 HIGH SPEED BUTTON**
When a high amount of steam or odours are produced, use the high speed setting for the most effective extraction.
- ★ LIGHT BUTTON**
Switches the light on and off.

CARE AND MAINTENANCE

IMPORTANT:

Before cleaning or maintenance please switch off the electricity supply and remove the plug from the wall.

REGULAR CLEANING:

Use a soft damp cloth with lukewarm mildly soapy water or household cleaning detergent. Never use metal pads, chemicals, abrasive material, abrasive cleaning creams or stiff brushes to clean the appliance.

CLEANING THE GREASE FILTER:

Clean the filter every month to help minimise the risk of fire. The filter collects grease, smoke and dust, therefore the filter is directly affecting the efficiency of the cooker hood. If not cleaned, the grease residue (which is potentially flammable) will saturate the filter. It can be easily cleaned with warm water and washing up liquid, alternatively the filters can be cleaned in your dishwasher. Please ensure no other items are washed with the filters, they must be washed separately to prevent food becoming trapped in the gauze. Cleaning the grease filters in the dishwasher may lead to discolouration, this is normal and is not a fault with the product.

REPLACING YOUR CHARCOAL FILTER:

This only applies if you are using the hood in recirculation mode (not vented to the outside). The charcoal filter traps your cooking odours and they need to be replaced, this can vary depending on how frequently the cooker hood is used. We recommend replacing them at least every 6 months.

This extractor uses CAP61CF charcoal filters. Filters can be purchased directly from **www.caple.co.uk**.

REPLACING THE BULB:

NOTE:

The lights must be replaced by a qualified person.

1. Switch the unit off and unplug the appliance.
2. Push out and unclip the old LED light.
3. Replace with the same type and rated bulb lamp fixing. LED lamp (max.1.5W).

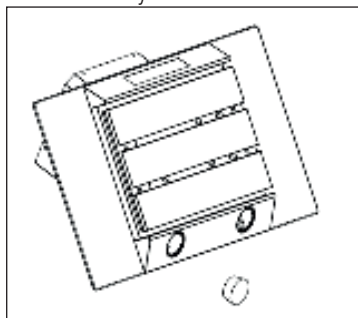

LIGHT SOURCE ENERGY CLASS

This product contains a light source of energy efficiency class G.

TROUBLESHOOTING

FAULT	CAUSE	SOLUTION
The lights on, but the fan does not work.	The fan blade is jammed.	Switch off the unit and contact Caple Service. To be repaired by qualified service personnel only.
	The motor is damaged.	
The lights and fan do not work.	A blown fuse.	Replace the fuse.
	The power cord is loose.	Plug in to the power supply again.
Serious vibration of the unit.	The fan blade is damaged.	Switch off the unit and contact Caple Service. To be repaired by qualified service personnel only.
	The fan motor is not fixed tightly..	Switch off the unit and contact Caple Service. To be repaired by qualified service personnel only.
	The unit is not hung correctly on the bracket.	Take down the unit and check whether the bracket is in the correct location.
The extraction performance is not good.	The filter requires cleaning.	Clean the grease filter as directed in the 'Care and maintenance' section. Replace the charcoal filter (if in recirculation mode).

If the above table has not solved the problem please contact Caple Service by phone on **0117 938 7420** or by email **service@caple.co.uk**

PRODUCT DIMENSIONS

SP612 & SP912

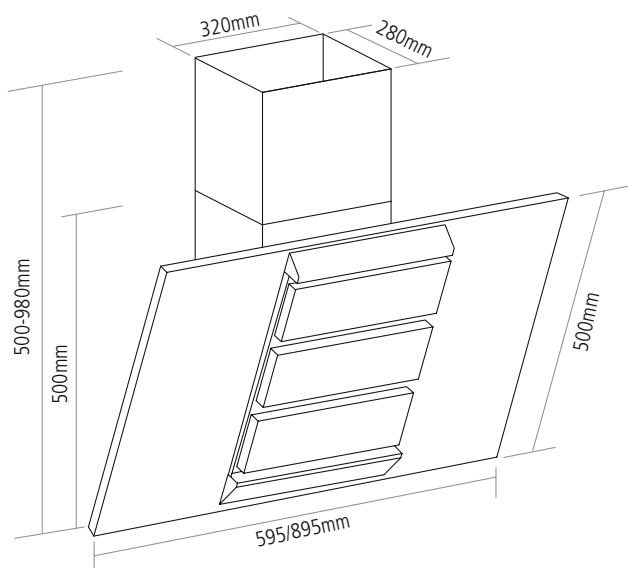



Caple Service

Fourth Way

Avonmouth

Bristol

BS11 8DW

T: 0117 938 1900

E: service@caple.co.uk

www.caple.co.uk