



50/50 FRIDGE FREEZER – FROST-FREE



PRODUCT CODE

Ri5505

DIMENSIONS

h: 1770mm

PERFORMANCE

Energy class A++
Energy consumption
235kWh/yr
Max. noise level 43dB[A]
3kg/24hrs freezing capacity

FINISH AVAILABLE

White

FEATURES

- Top LED strip light
- Electronic controls
- Adjustable thermostat
- Auto defrost [Fridge]
- Frost free [Freezer]
- Super cooling and freezing mode
- Caple cool air-flow system
- Caple fresh
- Humidity controlled drawer
- Adjustable door balcony
- 100% CFC/HFC free
- Reversible door
- Sliding door installation

DESIGN

- Deluxe steel trimmed interior
- Transparent plastic drawers and compartments

STORAGE

- 3 Door storage compartments
- 1 Drawer compartments [with humidity controls for fruit and vegetable storage]
- 3 Removable glass shelves, 1 Crisper cover shelf
- 4 Freezer drawers
- 1 Egg tray
- 1 Ice tray

CAPACITY

- 233 Litre total net capacity
- 249 Litre total gross capacity
- 147 Litre fridge net capacity
- 86 Litre freezer net capacity

DIMENSIONS

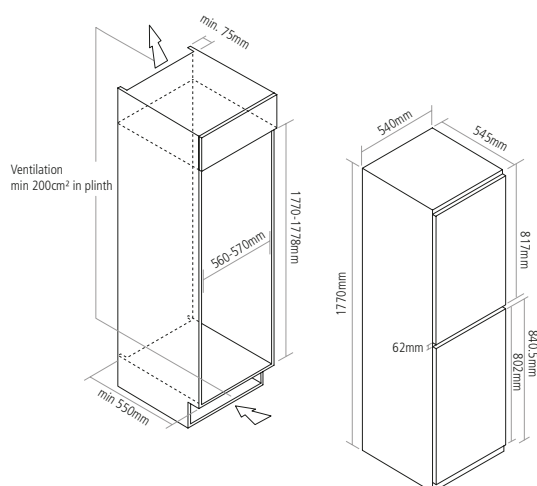

Features

FROST-FREE

No more laborious defrosting with a scraper. Our frost-free system works by heating up an element for a short time, which melts the ice and prevents build-up. Keeping a freezer ice-free means food stays fresher for longer. Freezing food is also much quicker, preserving as many nutrients as possible and freeing up much needed storage space.

GLASS SHELVES

Some of which have a deluxe steel trims to catch any spills.