



## DUMAS



### PRODUCT CODE

DUM/CH

### FINISH AVAILABLE

 Polished chrome

### GENERAL FEATURES

- Single lever design
- Minimum 0.3 bar pressure required
- Single lever ceramic valve
- Single flow

### ↔ DIMENSIONS

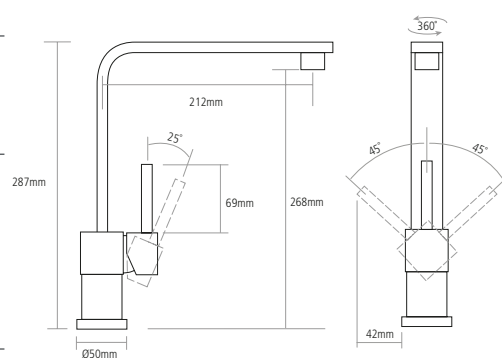

Worktop cut out 35mm required