

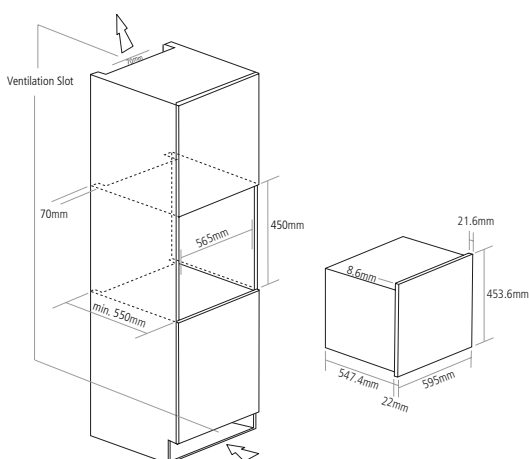

SENSE BUILT-IN COMBINATION MICROWAVE



DIMENSIONS



Features

TURNTABLE FREE DESIGN

Caple microwaves have been exquisitely designed to look the part. Some models have 40L capacity, removable dishwasher friendly glass base and a turntable free design. This means you can fit large dishes into the cavity.

PRODUCT CODE

S CM110

DIMENSIONS

h:450mm

FINISH AVAILABLE

Black glass with
Stainless steel trim

FUNCTIONS

10 Functions

- Light
- Microwave [10 power levels]
- Auto Defrost
- Turbo Grill
- Fan heat
- Turbo conventional
- Microwave and fan heat
- Microwave and turbo grill
- Microwave and conventional heat
- Auto cooking

FEATURES

- 40 Litre capacity
- Full touch control
- Programmable electronic timer
- Electronic clock
- Turntable free design
- Chrome shelf rack with 3 positions
- Internal light
- Double glazed removable door
- Child safety lock
- 8 Auto cooking programmes
- Auto-defrost

AUTO COOKING PROGRAMMES

- Milk
- Soup
- Vegetables
- Noodles
- Bread
- Fish
- Meat
- Chicken

DESIGN

- Stainless steel square bar handle
- Stainless steel interior
- White LED display

ACCESSORIES

- 1 Shelf
- 1 Baking tray
- 1 Glass base plate

INSTALLATION

- Rated load 2.55kW
- Fuse rating 13A

COOKING OUTPUT

- Microwave cooking 1000W