



CAPLE CARE

FREE 2 YEAR
PARTS & LABOUR
GUARANTEE

SENSE ELECTRIC SINGLE OVEN



MotionHeat+

DIMENSIONS

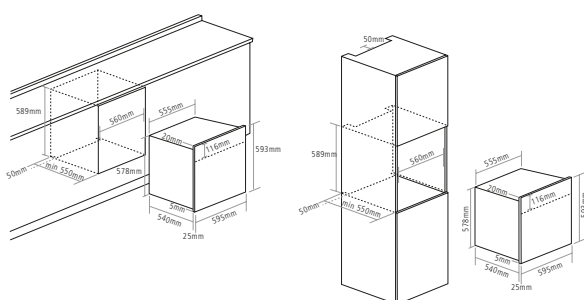

PRODUCT CODE

S C2101

DIMENSIONS

w:600mm

PERFORMANCE

e Energy class A

FINISH AVAILABLE

Black glass with
stainless steel trim

FUNCTIONS

10 Functions

- Light
- Base heat
- Conventional heat
- Fan heat
- Turbo conventional heat
- Full grill
- Eco grill
- Turbo grill
- Defrost
- Boost [rapid preheat]

OVEN FEATURES

- MotionHeat+ technology
- 67 Litre capacity
- Full touch control
- Programmable electronic timer
- Self-cleaning catalytic liners [back and sides]
- Easy clean enamel interior
- Two internal lights
- Closed door grilling
- Easy to remove chrome shelf racks
- Double glazed door
- Full width inner door glass
- Tangential cooling fan

DESIGN

- Square bar handle
- White LED display

ACCESSORIES

- 2 Safety-stop shelves
- 1 Grill pan with handle
- 2 sets of full extension telescopic runners

OPTIONAL EXTRAS

- 1 Wire shelf [SHELF4]
 - 1 Baking tray [TRAY3]
 - 1 Pizza stone [PIZZASTONE]
 - 1 Pizza peel [PIZZAPEEL]
 - 1 Air fry tray [AIRFRY]
 - Pair of full extension telescopic runners [CAPRACK8]
- Visit caple.co.uk for full range

INSTALLATION

- Rated load 3.22kW
- Fuse rating 16A