



BUILT-UNDER HOOD

PRODUCT CODE

BU521

DIMENSIONS

↔ w:520mm

PERFORMANCE

e Energy class B
Fluid Dynamic Efficiency B
Light Efficiency A
Grease Absorption B
Annual Consumption
58kWh/yr
Max. extraction 604m³/h
Max. noise level 70dB[A]

FEATURES

- Push button controls
- 3 Speeds
- 2 x 2.1w high intensity LED light
- Aluminium grease filter
- Required ducting size 150mm
- Recirculation kit available

OPTIONAL EXTRAS

- Recirculation kit [CAP66CF]
- Visit caple.co.uk for full range



DIMENSIONS

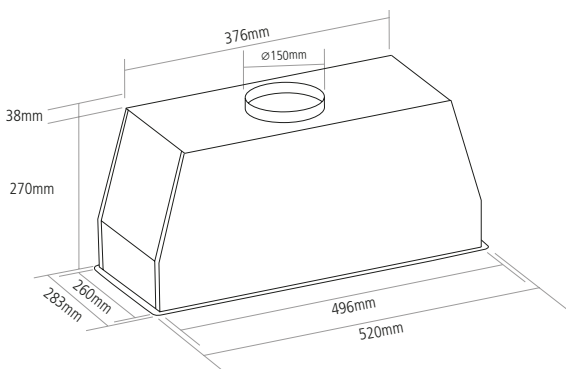

FINISH AVAILABLE

■ Stainless steel