

Instruction manual for ceiling hoods

Model code: CE1500



Model code: CE1101



Model code: CE1105



Model code: CE901



CONTENTS

Warnings

Uses

Installation

Working

Maintenance

WARNINGS

The appliance is not intended for use by young children or infirm persons without supervision. Young children should be supervised to ensure they do not play with the appliance.

The air sucked can't be conveyed through or into a duct used to let out fumes from appliances fed by energy other than electric power (eg. centralized heating, radiators, water-heaters, etc.).

To evacuate the air outlet, please comply with the pertaining rules given by competent authorities.

Provide the room with an adequate aeration when a cooker hood and appliances fed by energy other than electric power (gas-, oil-, or coal- stoves, etc.) are used simultaneously. The cooker hood, when evacuating the sucked air, could generate a negative pressure in the room- which can't exceed the limit of 0.04 mbar, in order to avoid the suck of exhausts deriving from the heat-source. Therefore the room should be provided with air-intakes to allow a constant flow of fresh air.

If the rating label in the cooker-hood shows the symbol , the appliance is built in class II° and it **does not need** any earth connection.

If the rating label in the cooker-hood **does not** show the symbol , the appliance is built in class I° and it **needs** the earth connection.

When performing the electrical connections on the appliance, please make sure that the current-tap is provided with earth connection and that voltage values correspond to those indicated on the label placed inside the appliance itself.

Before carrying out any cleaning or maintaining operations, the appliance needs to be removed from the electric grid.

If the appliance is not provided with a non-separable flexible cable and plug, or with

another device ensuring omnipolar disconnections from the grid, with an opening distance between the contacts of at least 3 mm, then such disconnecting devices must be supplied within the fixed installation.

If the appliance is endowed with a supply cord and a plug, the appliance has to be put in a place where the plug can be reached easily.

The use of materials which can burst into flames should be avoided in close proximity of the appliance. When frying, please pay particular attention to fire risk due to oil grease. Being highly inflammable, fried oil is especially dangerous. Do not use uncovered electric grills. In order to avoid possible fire risk, all instructions for grease-filter cleaning and for removing eventual grease deposits should be strictly followed.

USES

CE1500 - CE1101 - CE1105 - CE901 with external motors manufactured by the same producer.

PANELS OPENING

In CE1500, CE1101, CE901 models it is possible to open the steel panels, which cover the grease filters, by slightly pulling on a side of the panel itself, as shown in Fig. 3.

In CE1105 model, to open the panels you need to push the appropriate hooks placed on the sides of the panel, as shown in Fig. 11 and then rotating the panel downwards.

To achieve the complete opening of panels, you need to release the safety chains, by using the appropriate spring catches.

For proper working, it is recommended to install the appliance at a distance of 2000 – 2100 mm from the floor.

Before starting the appliance installation, please check that all components are not damaged, in such a case contact your retailer and do not carry out installation.

Furthermore, please read carefully all of the following installation instructions.

- Use an exhausting pipe whose maximum length does not exceed 5 meters.
- Limit the no. of elbows in the piping, since each elbow reduces the air capacity of 1 linear meter. (Ex.: if you use no. 2 x 90 ° elbows, the length of piping must not exceed 3 meters).
- Avoid abrupt direction changes.
- Use a 150 mm constant diameter pipe for the whole length.
- Use piping approved by standards in force.

INSTALLATION

CE1500 - CE1101 - CE1105 - CE901

Fit a false ceiling with an opening of the following sizes:

CE1500: 1465x965 mm with a minimum distance of 270 mm between the ceiling and the false ceiling;

CE1101: 1065x665 mm with a minimum distance of 270 mm between the ceiling and the false ceiling.

CE1105: 1050x645 mm with a minimum distance of 250 mm between the ceiling and the false ceiling;

CE901: 865x405 mm with a minimum distance of 270 mm between the ceiling and the false ceiling;

It is possible to select the side of the hood where the air suctioned can be discharged. After having chosen the most suitable position, prepare the ducting: an air outlet connection piece, with a diameter of 150 mm to be installed in the side selected, is provided with the appliance.

Leave any unused exhaust outlets closed.

Draw the outline of the hole to house the ceiling-mounted hood on the solid ceiling (Fig. 1), according to the model chosen; make 4 holes in the ceiling according to the dimensions shown in (Fig. 2); place the metric plugs provided in the holes.

Open the stainless steel panels, following the instructions mentioned in the USES section, and remove the grease filters in order to avoid damaging them in any way and to allow installation (Fig. 3); screw the threaded bars provided into the plugs (Fig.4); the threaded bars are 250 mm long and serve to install the ceiling-mounted hood at a distance from the solid ceiling of between 270 mm and 370 mm (Fig. 5); If the hood is installed with lateral air outlet, fit a false ceiling with an opening that has a minimum gap of 210 mm between the ceiling and the false ceiling (Fig. 12); in case of a larger gap between the hood and the ceiling, you need to use longer threaded bars.

Make the electrical connections and connect the air outlet pipe; place the ceiling-mounted hood into the niche, by inserting the threaded bars into the holes (Fig.6); the outer edge of the hood needs to be perfectly flush with the false ceiling. Insert the plates and nuts provided into the threaded bars, making sure to tighten them securely (Fig. 7); refit the grease filters and filter cover panels.

Connect the internal motor or the external motor's cable to the terminal board found inside the plastic box of the wiring . Make sure to respect the cables colours when performing the electrical connection (fig.16).

The "light" switch can turn the lights on and off. CE1500 CE1101: after the first touch of the light switch the lamps turn on at the maximum power. Keeping the switch pressed the intensity of the light decreases and then increases continuously. Leaving the switch the brightness remains set up. Touching again the light switch it is possible to turn the lamps off.

- To set the timer up press the button:



The LED on the right side will start to flash (every 5 seconds), the hood will work for 10 minutes at the selected speed and then it lights automatically off. If the client increases or reduces the speed while the timer is on, this is automatically stopped.

HOW TO USE

6 – channel radio control for cooker hood remote (fig. 10).

Technical data:

Alkaline battery powered: 12v mod. 23A

Operating frequency: 433.92 Mhz

Combinations: 4096

Max. consumption: 25mA

Operating temperature: -20° : +55°C

- To light the cooker hood on or to light it off press the button:



- To increase the speed up to the fourth one press the button:



- To reduce the speed up to the second one press the button:



- To go from a high speed back to the first one press twice the button:



- To give power to the lights or to shut them down press the button:



Standard configuration

If two cookerhoods-radiocontrol system are installed in the same room or in the immediate vicinity, each system may affect the operation of the other, due to the fact that they have the same code. Therefore it will be necessary to change the code of one of the radio controls.

Warning:

The battery should be replaced every year to guarantee the optimal range of the transmitter. To replace the exhausted battery, take the plastic lid off, remove the battery and replace it with a new one, observing the correct battery polarities. Used batteries should be discarded in special collection bins.

Generating a new transmission code

The radiocontrol is supplied by the manufacturer with default codes stored. If you want to create a new set of codes, proceed as follows:press and hold the UP, STOP and DOWN buttons simultaneously for 2 seconds. After the LEDS light up, press the UP and DOWN button swithin 5 seconds. The LEDS will flash 3 times to indicate that the process is completed.

WARNING: This procedure deletes all previously stored codes.

Learning the new transmission code

After changing the transmission code on the radio control, the cooker hood electronic control unit must be made to set the new code as follows: press the main Power Off button on the cookerhood (fig. 8) and then restore power to the electronic control unit. Within the next 15 seconds, press the Light button. This will ensure the control unit is synchronized with the new code.

TIMING

As a result of the new EU65 “Energy label” and EU66 “ Ecodesign” regulations issued by the European Commission, which came into force as from January 1st, 2015 , our products have been adapted to comply with these new requirements.

All of the models complying with the energy label requirements, are equipped with new electronics including a timer device for suction speeds control, when the air capacity exceeds $650\text{m}^3/\text{h}$.

Internal motor models, with maximum air capacity higher than $650\text{m}^3/\text{h}$, are equipped with a timer device that automatically switches the suction speed from 4th to 3rd speed, after 5 minutes operation.

External motor models are equipped with remote motors that , as for internal motor versions, include a timer device that switches down the suction speed when it exceeds $650\text{m}^3/\text{h}$. (See External Motors Instructions)

Remote motors, whose air capacity exceeds $650\text{m}^3/\text{h}$ at both 4th and 3rd speed , will have the following by default timer control functions:

The suction speed is automatically switched from 4th to 2nd speed, after 6 minutes operation.

If the appliance is working at 3rd speed, it is automatically switched to 2nd speed, after 7 minutes operation. Operation speeds can also be changed during operation.

The energy consumption of the appliance in stand - by mode is lower than 0.5W.

MAINTENANCE

An accurate maintenance guarantees good functioning and long-lasting performance.

A special care must be paid with grease filters: to remove the grease filter please follow the instructions given in the ‘USES’ section , according to the model chosen.

Remove the grease filter by pulling its handle.

To reinsert the grease filter after the cleaning, just perform the opposite operation.

Attention: after refastening the stainless steel panel make sure that it is properly fixed.

To clean the appliance itself tepid water and neutral detergents are recommended, while abrasive products must be avoided.

For steel appliances specialized detergents are recommended (please follow the instructions mentioned on the product itself to obtain the desired results).

To replace the lamp, (CE1500 – CE1101) remove the lamp (Fig. 9) and replace it with a lamp of the same kind.

To replace the fluorescent lamps (CE1105) you need to disconnect the appliance from the electrical network, then open the panel following the instructions given in the ‘USES’ section.

Remove the perimeter screws shown in fig. 13; pull the fluorescent lamps support out (fig.14), and replace the old lamp with a new one of the same kind.

Refit the panel and the screws previously removed.

To replace led strip (CE901)

Using an appropriate tool, remove the LED bar from its seat (refer to fig. 15), disconnect it electronically using the appropriate connector then substitute it with a LED bar with same characteristics.

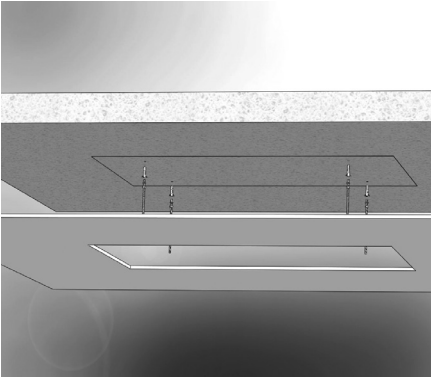

1

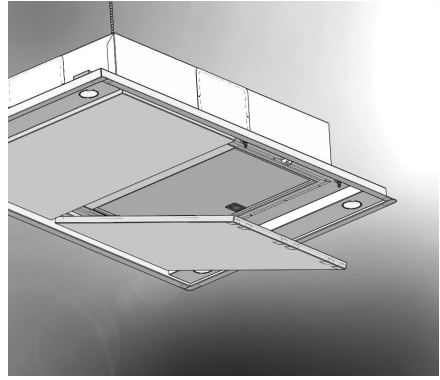

3

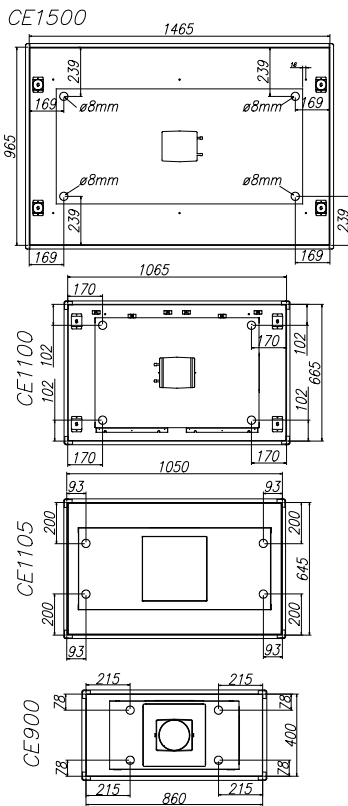

2

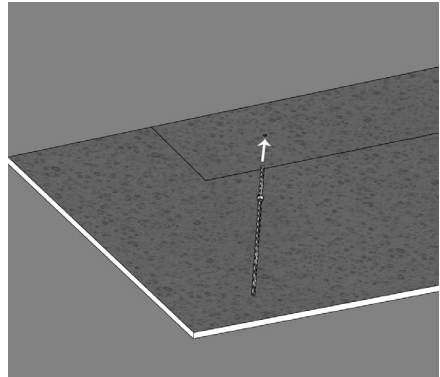

4

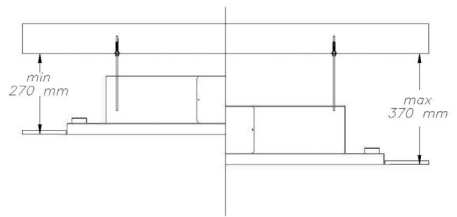

5

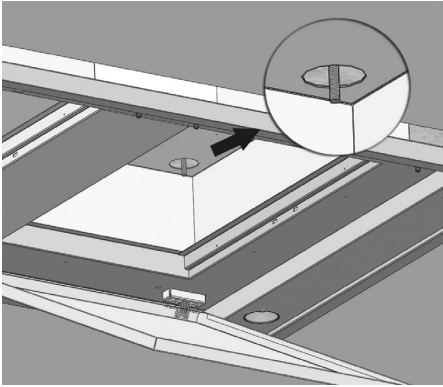

6

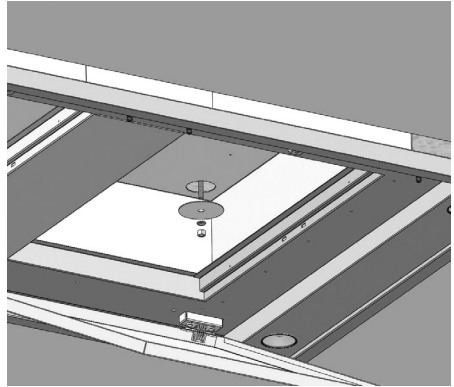

7

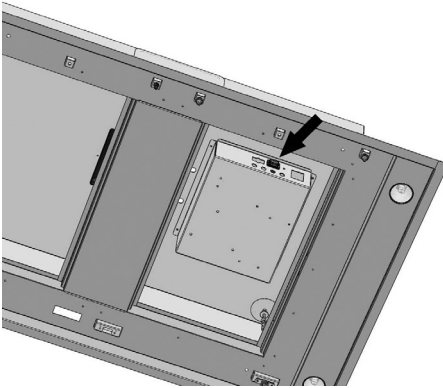

8

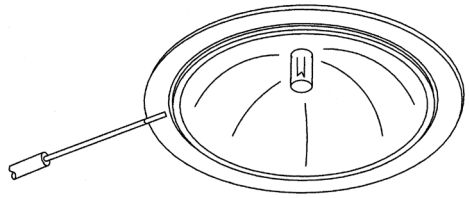

9



10

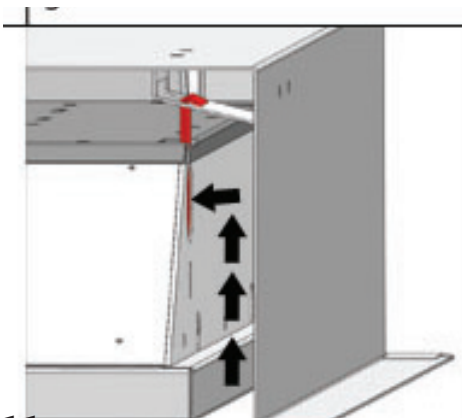

11

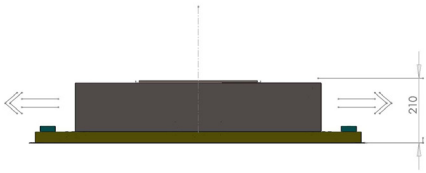

12

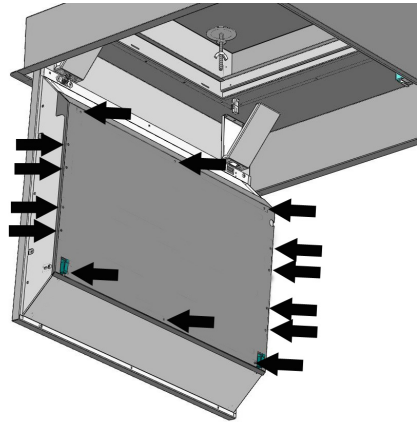

13

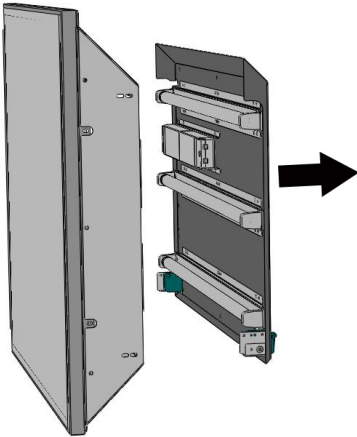

14

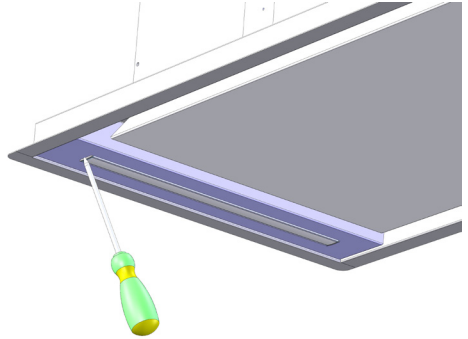

15

Energy label External motor

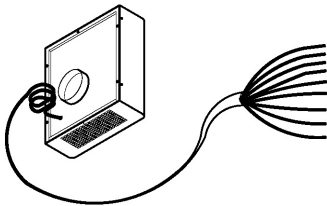

Energy label product in external motor version

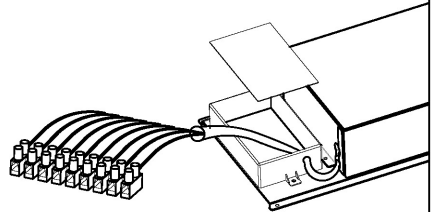

16

Serial number

Caple
Fourth Way
Avonmouth
Bristol
BS11 8DW
www.caple.co.uk